

Basler L400 and L800 Series



The L400 and L800 Line Scan Series

BASLER L400 AND L800 SERIES

Introduction

Basler offers a wide variety of line scan cameras to meet the diverse requirements of the marketplace. Monochrome and color cameras with resolutions from 1k to 8k and with line rates from 7 kHz to 58.5 kHz are available.

The L400 and L800 are equipped with top quality sensors that make them a perfect fit for applications where higher resolution is required. In addition, a high performance backend and an industrial grade housing make the L400 and L800 series versatile, reliable tools for many applications.

Features and Benefits of the L400 and L800 Variants

The L400 and L800 series of digital line scan cameras is designed for industrial users who require high resolution with high-speed data acquisition. A standard Camera Link® interface simplifies system integration and gives you increased flexibility when changing cameras or frame grabbers. The compact industrial grade housing, a combination of useful features, and the Windows setup tool guarantee easy integration in your application.

L400 and L800 high performance cameras are a perfect fit for a variety of vision applications including printed circuit board inspection, flat panel display inspection, postal sorting and document scanning, print inspection, web inspection, food inspection, and many others.



Your benefits include:

- High sensitivity combined with an exceptional signal-to-noise ratio
- 4080 pixel resolution with line rates up to 14.1 kHz with the L400 variants
- 8160 pixel resolution with line rates up to 14.1 kHz with the L800 variants
- A small, rugged housing designed for use in industrial equipment.
- LED indicators and test image generation capabilities reduce your integration time and troubleshooting
- Windows® setup tool (CCT+) lets you configure your camera with ease
- 100% quality checked and calibrated to give you consistent performance and reliability
- Useful features such as a line sum, a line counter, and shading correction enhance your range of application solutions

Camera Link®

Camera Link is a communication link for visual applications in the fields of science and industry. It was founded in the year 2000 by the leading companies in the machine vision arena. Camera Link enables a maximum data transmission rate of 680 MB per second depending on the configuration. Frame grabbers which collect and evaluate the data are usually used to connect the camera and the PC via the Camera Link interface.

The most important benefits afforded by Camera Link are:

- Accepted communication standard for vision technologies (camera frame grabber)
- Simple and standardized cable concept
- Particular suitability for high data rates
- Standardized data protocol for several types of data transfer, for example single/dual tap, 8 bit, 10 bit, RGB, etc.
- Serial communication to the camera via the frame grabber communication port

The Camera Link standard means that many frame grabbers produced by different vendors are compatible with the L400 and L800 cameras. These vendors are for instance: Cognex, Matrox, National Instruments, Euresys, Matrix Vision, BitFlow, Mikrotron. An overview with more frame grabber vendors and the compatible frame grabber can be found at the webpage www.basler-vc.com.



TECHNICAL DETAILS

Specifications

Basler L400 and L800 Series	L401k	L402k	L801k	L802k	L803k
Camera					
Sensor Size	4080 pixels	4080 pixels	8160 pixels	8160 pixels	8160 pixels
Sensor Type	Linear CCD				
Pixel Size	10 μm x 5 μm (10 μm pitch)	10 μm x 5 μm (10 μm pitch)	5 μm x 5 μm (5 μm pitch)	5 μm x 5 μm (5 μm pitch)	5 μm x 5 μm (5 μm pitch)
Camera Link Pixel Clock (MHz)	30	30	20	40	60
Max. Data Rate (MPixels/s)	28	56	37	75	112
Max. Line Rate (KHz)	7.1	14.1	4.7	9.4	14.1
Pixel Depths	Selectable 8 bit or 10 bit				
Video Output Formats	Single tap 8 bit or single tap 10 bit	Dual tap 8 bit or dual tap 10 bit	Dual tap 8 bit or dual tap 10 bit	Dual tap 8 bit or dual tap 10 bit	Dual tap 8 bit or dual tap 10 bit
Synchronizations	Via external signal or free run				
Exposure Control Models	Edge-controlled, level controlled, or programmable				
Mechanical / Electrical					
Power Requirements	12 VDC +/- 10% max. 6 W @ 12 VDC	12 VDC +/- 10% max. 7 W @ 12 VDC	12 VDC +/- 10% max. 5 W @ 12 VDC	12 VDC +/- 10% max. 6 W @ 12 VDC	12 VDC +/- 10% max. 7 W @ 12 VDC
Lens Mounts	F- mount				
Housing Size (L x W x H)	41.3 mm x 71.0 mm x 71.0 mm (without lens adapter)				
Weight	~ 300 g (without F-mount adapter)				
Conformity	CE and FCC				
Accessories	Optional heat sink available				

Specifications may change without prior notice

Dimensions (in mm)

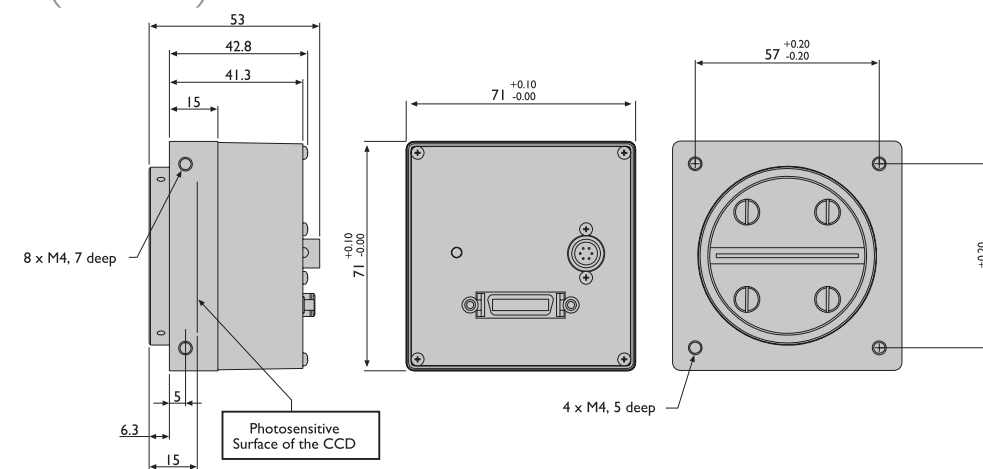

OTHER INFORMATION

What Makes Basler Camera Quality so Special?



Basler Camera Test Tool

To ensure consistently high product quality, we employ several quality inspection procedures during manufacturing. This list describes three of the most essential actions we take to meet your highest requirements.

- The back focal length on each camera is carefully measured and adjusted. This guarantees an optimum distance between the lens flange and the sensor and compliance to optics standards.
- Our advanced Camera Test Tool (CTT+), the first fully-automated inspection system for digital cameras, checks all of the significant quality aspects of each camera we produce. The CTT+ is a unique combination of optics, hardware, and software that can be quickly and efficiently used to calibrate a camera and to measure its performance against a set of standards. For defined sets of conditions, an automated software program examines the camera's output, makes any calibration adjustments necessary, and compares the output to a strictly defined set of performance criteria.
- As a final check, our cameras must pass a stress test. Each camera is tested over the entire temperature range specified in our documentation. By doing this, we can identify and remove temperature sensitive weak spots in the camera. Thus, consistent image quality in conditions with quickly changing temperatures is guaranteed.

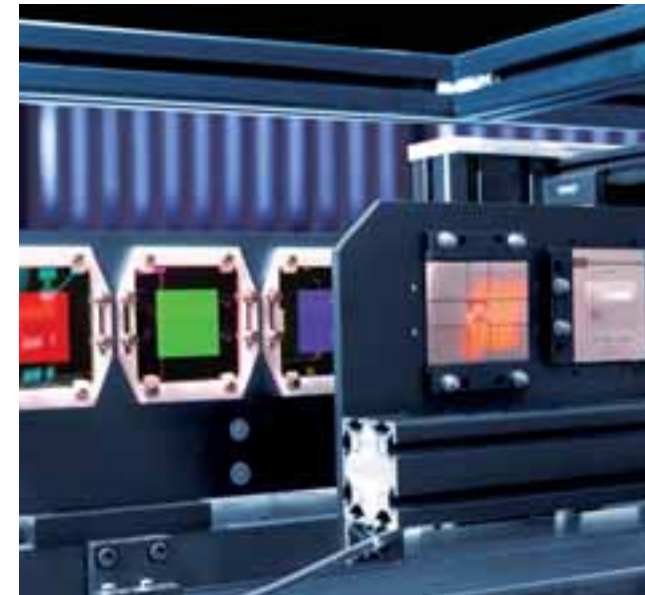



Germany, Headquarters
Fon +49 4102 463 500
Fax +49 4102 463 599
vc.sales.europe@baslerweb.com

USA
Fon +1 610 280 0171
Fax +1 610 280 7608
vc.sales.usa@baslerweb.com

Singapore
Fon +65 6425 0472
Fax +65 6425 0473
vc.sales.asia@baslerweb.com

www.basler-vc.com

BASLER
VISION TECHNOLOGIES

© 2016 BASLER VISION COMPONENTS