

Basler eXcite



The Intelligent Camera Series

What Makes Basler Camera Quality So Special?



To ensure consistently high product quality, we employ several quality inspection procedures during manufacturing. This list describes some of the most essential actions we take to meet your highest requirements.

- The back focal length on each camera is carefully measured and adjusted. This guarantees an optimum distance between the lens flange and the sensor and ensures compliance with optics standards.
- Our advanced Camera Test Tool (CTT+), the first fully-automated inspection system for digital cameras, checks all of the significant quality aspects of each camera we produce. The CTT+ is a unique combination of optics, hardware, and software that can be quickly and efficiently used to calibrate a camera and to measure its performance against a set of standards. For defined sets of conditions, an automated software program examines the camera's output, makes any calibration adjustments necessary, and compares the output to a strictly defined set of performance criteria.



The Basler eXcite is measured by the CTT+ according to the EMVA 1288 standard

RoHS Compliance

The Basler eXcite family is RoHS compliant. This is especially important in applications where the end user requires strict RoHS compliance in all system components.



Can You Create New Market Opportunities with a Small, Powerful Vision Engine?

Basler's eXcite family merges our superior digital camera technology and a high-performance PC in one small housing. The eXcite offers a single component capable of both capturing and processing images based on your application software.

The 1.0 GHz performance provides the power for complex, high-speed image processing. With a choice of ten different camera sensor types, the eXcite is ideal for use in a wide range of applications such as exact measurement and positioning and inspection and identification. Using the eXcite's variety of integrated communications interfaces, including eight digital I/O ports, super-fast Gigabit Ethernet, and high speed USB 2.0, calculated results can be fed directly back into a production process without the need for additional hardware components. You could use this capability, for example, to trigger the removal of defective parts from a production line. The small, rugged housing of the eXcite makes integration easy in most locations.

Your benefits include:

- 1.0 GHz performance for your image processing applications
- An open, flexible platform running a Linux OS
- Resolutions from VGA to 2 megapixels and up to 12 bit data depths
- High speed image capture at up to 180 fps at VGA resolution
- A small, rugged housing
- Versatile communications interfaces, such as GigE, USB 2.0, and digital I/Os, support easy integration
- 100% quality checked and calibrated to give you consistent performance and reliability

Capturing

Basler's years of experience in camera design are demonstrated by the high image quality of the eXcite. The range of available camera sensors starts with VGA resolution and an image capture rate of up to 180 frames per second (fps). The 1.45 and 2.0 megapixel CCD sensor models can achieve 17.8 and 14 fps respectively. All eXcite models are available in both monochrome and color. A separate microcontroller handles all internal camera functions including configuring and capturing, so reliable operation is guaranteed independent of the image processing load. Additional pre-processing, such as YUV color conversion, is done by an FPGA. And of course, all of our standard camera features including an electronic full frame shutter, area of interest (AOI) scanning, and real-time triggering are available on the eXcite.

Processing

The core of the eXcite, a 64 bit processor running at a 1.0 GHz clock frequency, provides the required performance for complex, high-speed image processing. The use of a Linux operating system allows the hardware to run at its top level. With your full access to the Linux OS, you can adapt the camera to a wide range of application specific requirements.

Application Development

The eXcite family serves as an open hardware platform for your software applications. The eXcite's "SDK Tool Collection" contains everything needed to support you during your software development process.

The PCViewerTool helps you find the best setup for your application. With this tool, all of the camera's parameter settings can be changed via a TCP/IP connection while a live view of captured images is displayed.

To run your application at its best performance level, the camera's processor hardware requires a recompilation of your C++ software. The compiler, linker, and debugger in the GNU* tool chain, as configured by Basler, forces this output. These software tools are integrated in Eclipse**, Basler's recommended development environment for the eXcite. The included standard software libraries support all common C/C++ methods. For direct graphical output, X11 services are also available on the camera.

Your development PC can have either a Linux or a Windows XP operating system. If you have Windows XP, you can use the coLinux program to emulate the required Linux environment.

Extensive documentation and sample programs show you how to use the camera's API and minimize your learning time. The eXcite's SDK Tool Collection includes a DVD-based installation package for all tools, which simplifies your first steps with the eXcite.

* for more information see www.gnu.org

** for more information see www.eclipse.org

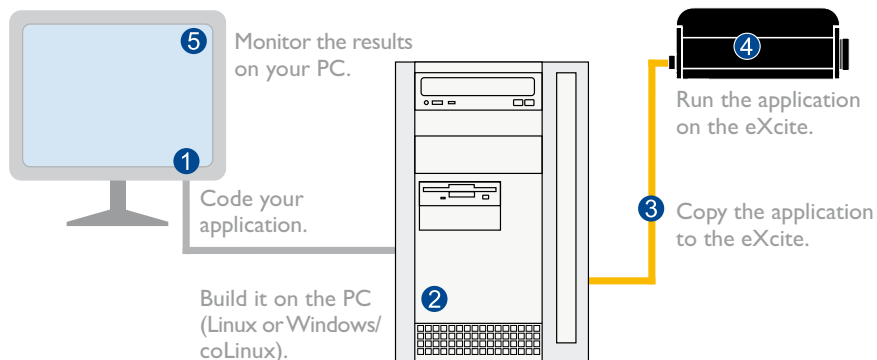

Connection

Given the versatile interfaces on the eXcite, communication with the external environment can be accomplished in many different ways. The Gigabit Ethernet interface provides ample bandwidth to allow continuous and uninterrupted transfer of high data volumes between devices on a LAN. The devices can be standard PCs or other eXcite cameras. The eXcite's USB 2.0 interface supports on-the-fly connection of additional hardware. In addition to supplying a connection point for a keyboard and mouse, the USB 2.0 interface supports the exchange of data in the field via a flash drive or a disk drive. A connection to a PLC can be established via the serial RS-232 interface or via the freely configurable digital I/O ports. All digital I/O ports are opto-isolated to help ensure safe processing.



Heat Sink Housing Variant – Back Side

System Integration

All eXcite models are available in two different housing variants. The contact plane variant focuses on machine vision applications where sufficient heat dissipation can be achieved via direct contact with production equipment. The integrated heat sink housing variant is focused on tripod applications. In all cases, the eXcite's integrated temperature monitor will prevent damage to the device from overheating.

A power supply and all of the cables required for easy system integration are available from Basler. Please refer to the list of accessories.



Contact Plane (cp) Housing Variant

Specifications

Basler eXcite	exA640-60m (cp) exA640-60c (cp)	exA640-120m (cp) exA640-120c (cp)	exA640-180m (cp) exA640-180c (cp)	exA1390-19m (cp) exA1390-19c (cp)	exA1600-14m (cp) exA1600-14c (cp)
Camera Section					
Resolution	Mono: 656 x 491 Color: 656 x 490	Mono: 656 x 491 Color: 656 x 490	Mono: 656 x 491 Color: 656 x 490	Mono: 1392 x 1040 Color: 1388 x 1038	Mono: 1624 x 1236 Color: 1624 x 1234
Sensor Type	CMOS	CMOS	CMOS	CCD	CCD
Pixel Size	9.9 µm x 9.9 µm	9.9 µm x 9.9 µm	9.9 µm x 9.9 µm	4.65 µm x 4.65 µm	4.4 µm x 4.4 µm
Frame Rate at Full Resolution	60 fps	132 fps	176 fps	18.7 fps	14 fps
Mono/Color	Mono or Color				
Video Output Format	Mono: 8, 10 bit/pixel Color (8 bit/pixel): YUV4:2:2, Raw, Mono Color (10 bit/pixel): Raw, Mono	Mono: 8, 10 bit/pixel Color (8 bit/pixel): YUV4:2:2, Raw, Mono Color (10 bit/pixel): Raw, Mono	Mono: 8 bit/pixel Color (8 bit/pixel): Raw, Mono	Mono: 8, 12 bit/pixel Color (8 bit/pixel): YUV4:2:2, Raw, Mono Color (12 bit/pixel): Raw, Mono	Mono: 8, 12 bit/pixel Color (8 bit/pixel): YUV4:2:2, Raw, Mono Color (12 bit/pixel): Raw, Mono
Synchronization	Via external trigger or via software				
Processor Section					
CPU Type	64 bit-Mips Processor				
Speed	1.0 GHz				
RAM / Flash	128 MB / 128 MB				
OS	Linux (Kernel 2.6)				
Interface					
USB	2 x Version 2.0				
LAN	10 / 100 / 1000 MBit				
Serial	RS-232, max 115 kBaud				
Digital IO	4 x In, 4 x Out, opto-coupled, 10-30VDC				
Mechanical / Electrical					
Housing Size (LxWxH)	Heat sink variant: 150 mm x 55 mm x 60 mm, contact plane variant: 150 mm x 72 mm x 45 mm				
Weight	600 g typical				
Power Requirements	12VDC, 14W (Typical) @ 12VDC				
Operation Temperature	0°C ...+45°C (+32°F...+113°F) housing temperature				
Operation Humidity	20%...80%, relative, non-condensing				
Mount Type	C-mount				
Certifications	CE, FCC				
Software Environment					
Configuration Tools	Basler Camera Configuration Tool, Viewer GX, Telnet and FTP services				
Development Tools	Eclipse, GNU Tools, coLinux				
PC Requirements	Linux (2.4 or higher) or Windows XP; Ethernet port				

Specifications are subject to change without prior notice.

Dimensions (in mm)

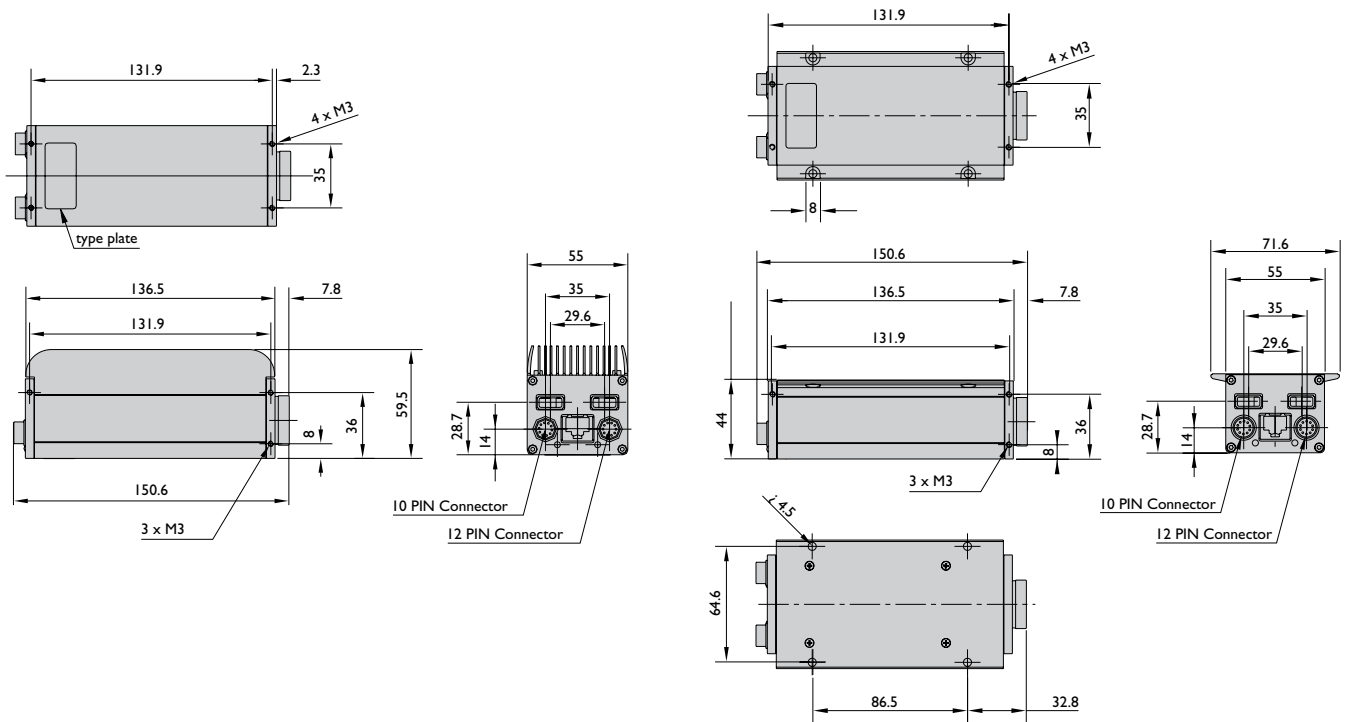

List of Accessories

The starter kit contains all of the required accessories for common setups. It is ideal for eXcite beginners.

Accessories	Comment	Included in the Starter Kit
Power Supply	Output: 12V, 2.5 A max Input : 110 – 250VAC, 50-60 Hz	Yes
RS-232 Y-Cable	Splits out a line for input power and a line for the RS-232 serial communications interface	Yes
Digital I/O Cable	Hirose 12 pin connector on one end and unterminated on the other, 5 meters	Yes
Fan Kit	Recommended for the heat sink housing variant	Yes
RS-232 Null-modem Cable	Used together with the Y-Cable to establish RS-232 communication	Yes
Patch Cable	Standard CAT 5e Ethernet cable, 2 meters	Yes
eXcite SDK Tool Collection	This free DVD contains all of the tools needed for software program development.	Yes
Power Connector	Hirose 10 pin plug (female)	No
Digital I/O Connector	Hirose 12 pin plug (female)	No
Tripod Mount Plate	Provides the screw hole for a tripod	No



www.baslerweb.com

Germany, Headquarters

Phone +49 4102 463 500
Fax +49 4102 463 599
bc.sales.europe@baslerweb.com

USA

Phone +1 610 280 0171
Fax +1 610 280 7608
bc.sales.usa@baslerweb.com

Singapore

Phone +65 6425 0472
Fax +65 6425 0473
bc.sales.asia@baslerweb.com