

Basler A601f, A602f, and A622f



Small, Powerful, Easy to Use

A601f, A602f, and A622f - Cost Effective Digital Solutions



A601f, A602f, and A622f cameras have an exceptional price/performance ratio and are designed to achieve the optimum in performance, durability, and value. Their compact size and the ease of integration associated with their FireWire interface make these cameras ideal for analog users seeking the advantages of digital video. They are a major force in the "analog goes digital" trend.

Your benefits from the Basler A601f, A602f and A622f include:

- A small, rugged housing with a 29 x 44 mm footprint for easy integration
- Up to 100 fps at VGA resolution
- Up to 25 fps at 1.3 megapixel resolution
- Selected CMOS global shutter image sensors
- A plug-and-play IEEE 1394 interface combined with an easy-to-use Basler BCAM driver saves you time
- Free download of our BCAM viewer
- 100% quality checked and calibrated to give you consistent performance and reliability

With their flexible design, these high-performance cameras are a perfect fit for a wide range of vision applications.

Fastest FireWire-a Camera

Cameras in this family can capture up to 100 frames per second at VGA resolution, the fastest speed possible with a FireWire-a interface. This high image capture rate combined with fast I/O handling inside of the camera makes the A602f/fc ideal for demanding high speed applications.

The FireWire Advantage

FireWire, also known as IEEE 1394, has become a standard image data and camera command transmission mechanism in the machine vision industry. Its key benefit is real-time communication between your camera and remote computer at 400 Mbit/s (with FireWire-a). FireWire integration is easy, cost-effective, and standardized. It supports plug-and-play and there is no need for a frame grabber.

One Shot Operation and Software Trigger

The cameras let you use the 1394 bus to "trigger" image capture without the need for a hardware generated signal.

In "one shot" operating mode, the camera normally exposes and transmits a single image based on user defined parameters that are transmitted to the camera. This operating mode usually results in the start of image exposure within an acceptable amount of time. But to get an even quicker response, you can use a "software trigger" to start grabbing a single image exactly when it is needed by your application.

Trigger Ready

The Trigger Ready feature is a Basler patented innovation. It lets you optimize your image capture timing by monitoring the current camera settings and calculating the earliest moment each exposure can begin.

By using the Trigger Ready signal, you can easily operate at the maximum frame rate allowed with the current camera settings. It also prevents you from running the camera faster than allowed and avoids dropping or losing images.

Board Level Version

The A601f/fc and A602f/fc are available as a board level design for more versatility and cost-effectiveness.

Color Coding and Preprocessing

A601fc and A602fc color cameras feature various modes of color coding for maximum flexibility in color representation. YUV 4:2:2 color coding is done inside of the camera and YUV image data can be obtained directly via the 1394 bus. For individual processing, each pixel value can be read out separately in raw mode at 8 or 12 bit depth and can be processed as desired in your remote computer. The A622f is available in monochrome only.

Basler Camera Software

BCAM Driver and SDK Package

When combined with an A601f, A602f, or A622f camera, the BCAM driver offers our users a robust, plug-and-play solution with exceptional performance. Integration is easy and problems with matching cables and creating interface files are eliminated. The driver has been extensively tested with a variety of 1394 interface boards to offer you a new level of reliability. The BCAM SDK package provides easy-to-use low level and high level C++ APIs on top of the driver. The APIs provide access to your camera's full functionality (e.g., grabbing images and configuring the camera) with Visual Studio and Visual Studio.NET. In addition, the SDK package offers DirectX support via a DirectShow Video Source filter and includes DirectX source code samples for both Visual C++ and

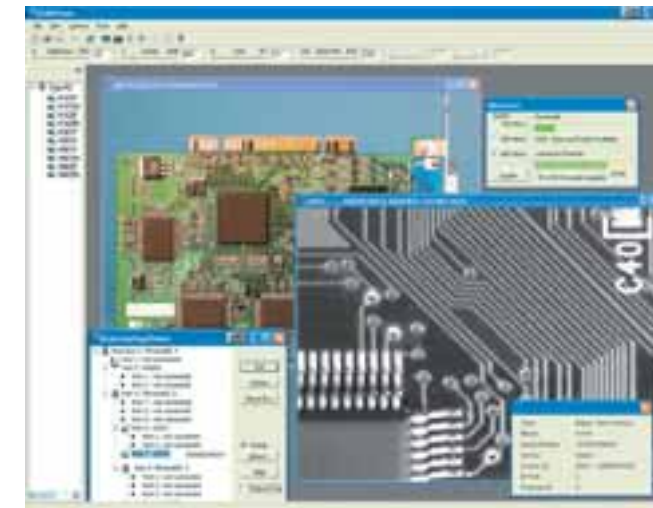

Visual Basic.

The SDK's API is fully documented and comes with complete source code for the user mode driver. A collection of code samples demonstrates and explains how to use the SDK. The SDK package also includes some helpful tools (along with the source code for each tool) such as:

- **The BCAM Viewer - an integrated camera viewer program for grabbing images and for configuring the camera**
- **The BCAM Topology Viewer (for Windows XP only) - a bus topology viewer program that lets you quickly evaluate the state of the 1394 bus and the availability of bus resources**

Smart Features Framework (SFF)

When used with the BCAM Driver, the Smart Features Framework provides access to the smart features included on Basler IEEE 1394 cameras. Basler's smart features extend the standard IIDC feature set and offer capabilities like:

- **An Extended Data Stream that adds information about the current camera settings – such as shutter, AOI, offset, etc. – to the basic image data for each captured image**
- **A CRC Checksum for the image data**
- **A Frame Counter and Time Stamp for each captured image**
- **Uploading of a Lookup Table to the camera**
- **Lossless Compression of image data**
- **Digital I/O Configuration**

A GUI called the "SFF Viewer/Configurator" is included with the Smart Features Framework. The GUI is used to configure your camera's smart features and for grabbing images. The SFF also includes a C API along with some sample applications that explain and demonstrate the use of the API.

Third Party Image Libraries and Software

All Basler 1394 cameras are compliant with the 1394 Trade Association's DCAM standard. DCAM defines standardized methods for exchanging data and commands between 1394 cameras and computers. All image libraries and software packages compliant with DCAM will work with Basler 1394 cameras. The integration of an A601f, A602f, or A622f camera with DCAM compliant software is as easy as can be.

A selection of companies offering third party products is shown below. Many other products are also available.

- **Cognex**
- **Matrox Imaging**
- **National Instruments**
- **Stemmer**
- **Euresys**
- **MVTec**
- **Neurocheck**

How Does Basler Measure and Define Image Quality?

1288
EMVA Standard Compliant

Basler-VC is leading the effort to standardize image quality and sensitivity measurement for machine vision cameras and sensors. All measurements done by Basler will be in 100% compliance with the new European Machine Vision Association EMVA 1288 standard. Because it describes a unified method to measure, compute, and

present the specification parameters for cameras and image sensors used in machine vision applications, Basler is giving the EMVA 1288 standard our strongest support. In the future, we will routinely provide compliant information about the quality and sensitivity of our products.

The following charts and parameters are extracted from standardized quality and measurement processes used by the CTT+.

Quantum Efficiency

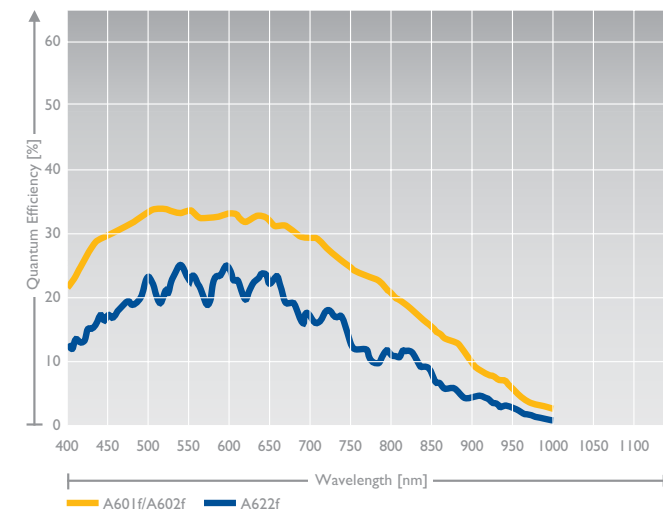

Sensitivity Parameters*

Sensitivity Parameters	A601f/A602f	A622f
Quantum efficiency @ 545nm (%)	32	23
Dark noise (e-)	113	54
Saturation capacity (e-)	50000	31000
Maximum signal-to-noise ratio (bits) (dB)	7.8	7.5
Absolute sensitivity @ 545 nm (photons)	352	231
Photo saturation capacity @ 545 nm (photons)	156000	132000
Dynamic range (bit) (dB)	8.8	9.2

Signal-to-Noise Ratio (dB)*

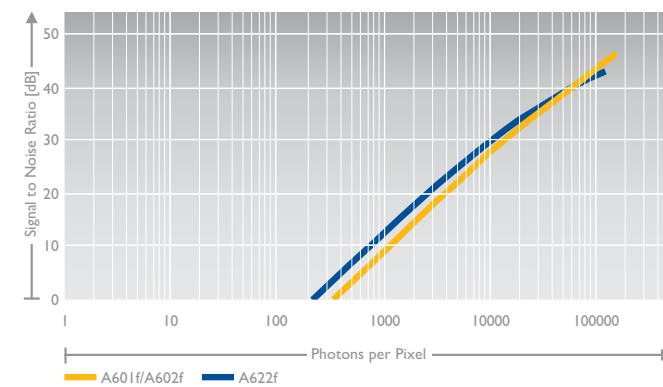

Signal-to-Noise Ratio (bits)*

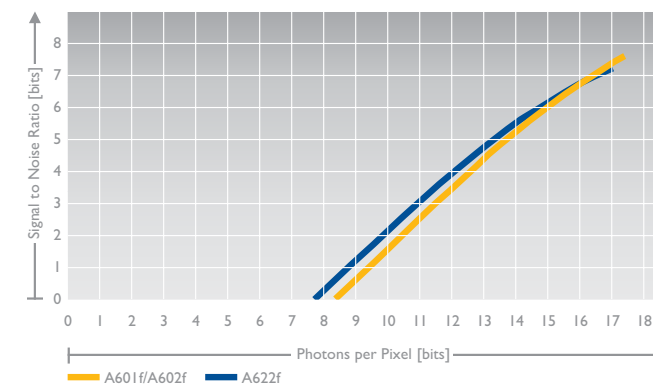

* All values are typical. Change without prior notice

TECHNICAL DETAILS

Specifications

Basler	A601/A602f	A601fc/A602fc	A622f
Camera			
Resolution	656 x 491	656 x 490	1280 x 1024
Sensor Type	CMOS, global shutter, progressive scan		
Pixel Size (µm)	9.9 x 9.9	9.9 x 9.9	6.7 x 6.7
Frame Rate at Full Resolution	60 fps / 100 fps	60 fps / 100 fps	25 fps
Mono/Color	Mono	Color	Mono
Video Output Type	IEEE1394a	IEEE1394a	IEEE1394a
Video Output Format	Mono 8: 8 bits/pixel Mono 16: 10 bits/pixel	YUV 4:2:2: 16 bits/pixel Raw 8: 8 bits/pixel (R,G, or B): Raw 16: 10 bits/pixel (R,G, or B)	Mono 8: 8 bits/pixel Mono 16: 10 bits/pixel Pseudo YUV 4:2:2: 16 bits/pixel
Gain Control	0-12 dB	0-12 dB	0-20.2 dB
Synchronization	Via external trigger, via the 1394 bus, or free run		
Exposure Control	Programmable via the 1394 bus		
Mechanical / Electrical			
Housing Size (L x W x H)	67.3 mm x 44 mm x 29 mm without lens adapter		
Housing Alternatives	Board level version available	Board level version available	–
Weight	ca. 100 g		
Power Requirements	8-36 VDC, max. 1.7 W (at 12 VDC) via 1394 cable	8-36 VDC, max. 1.7 W (at 12 VDC) via 1394 cable	8-36 VDC, max. 2.3 W (at 12 VDC) via 1394 cable
Mount Type	C-mount		
Conformity	CE, FCC		
Software and Features			
Camera Features	Freely programmable area of interest (AOI), trigger ready, look up tables (programmable), lossless compression, and many other included in the Smart Features Framework (SFF)		
Software	BCAM Driver, SDK Package, and SFF		

Specifications are subject to change without prior notice

Dimensions (in mm)

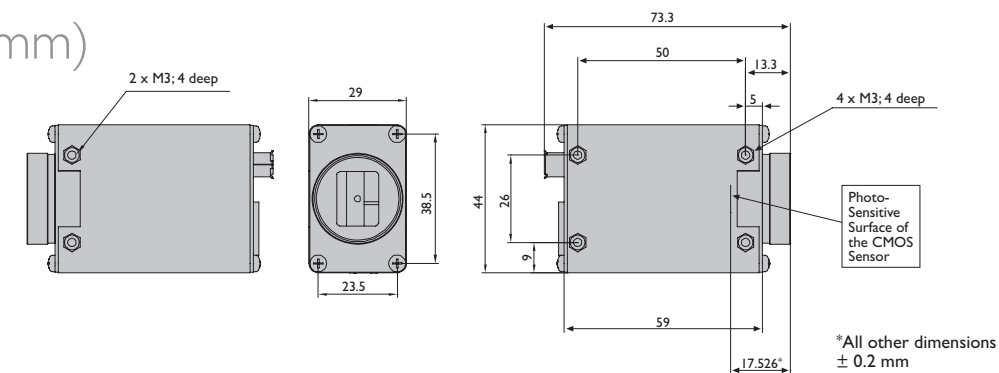



Basler Camera Test Tool

To ensure consistently high product quality, we employ several quality inspection procedures during manufacturing. This list describes three of the most essential actions we take to meet your highest requirements.

- The back focal length on each camera is carefully measured and adjusted. This guarantees an optimum distance between the lens flange and the sensor and compliance to optics standards.
- Our advanced Camera Test Tool (CTT+), the first fully-automated inspection system for digital cameras, checks all of the significant quality aspects of each camera we produce. The CTT+ is a unique combination of optics, hardware, and software that can be quickly and efficiently used to calibrate a camera and to measure its performance against a set of standards. For defined sets of conditions, an automated software program examines the camera's output, makes any calibration adjustments necessary, and compares the output to a strictly defined set of performance criteria.
- As a final check, our cameras must pass a stress test. Each camera is tested over the entire temperature range specified in our documentation. By doing this, we can identify and remove temperature sensitive weak spots in the camera. Thus, consistent image quality in conditions with quickly changing temperatures is guaranteed.

Basler customers get a 100% tested camera, all of the benefits that go along with 100% testing, and a much higher level of satisfaction. This is a definite win-win situation.

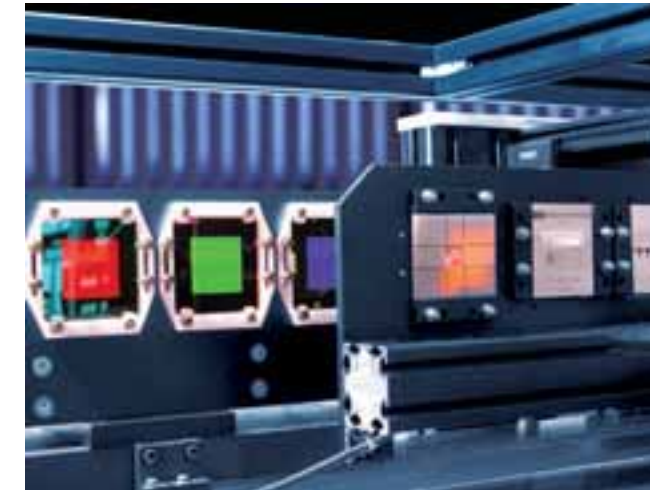

Cameras are measured by the CTT+ according to the EMVA 1288 standard



www.basler-vc.com

Germany, Headquarters
Fon +49 4102 463 500
Fax +49 4102 463 599
vc.sales.europe@baslerweb.com

USA
Fon +1 610 280 0171
Fax +1 610 280 7608
vc.sales.usa@baslerweb.com

Singapore
Fon +65 6425 0472
Fax +65 6425 0473
vc.sales.asia@baslerweb.com